

Open Core Protocol (OCP)

An Introduction to Interface Specification

Prashant D. Karandikar
Texas Instruments Inc

Chair, OCP-IP Meta Data Working Group

Jan 10 2010

1st Workshop on SoC Architecture, Accelerators & Workloads

Agenda

- Introduction
- Key OCP3.0 Features
 - 2D addressing
 - SRMD vs MRMD
 - Tagging vs Threading
 - Connection Protocol
 - Cache Coherency
- Interface Specification
 - OCP Vendor Extension
 - OCP Abstraction Definition
 - OCP Bus Definition
 - OCP Checkers
- Conclusion

Bus Protocol

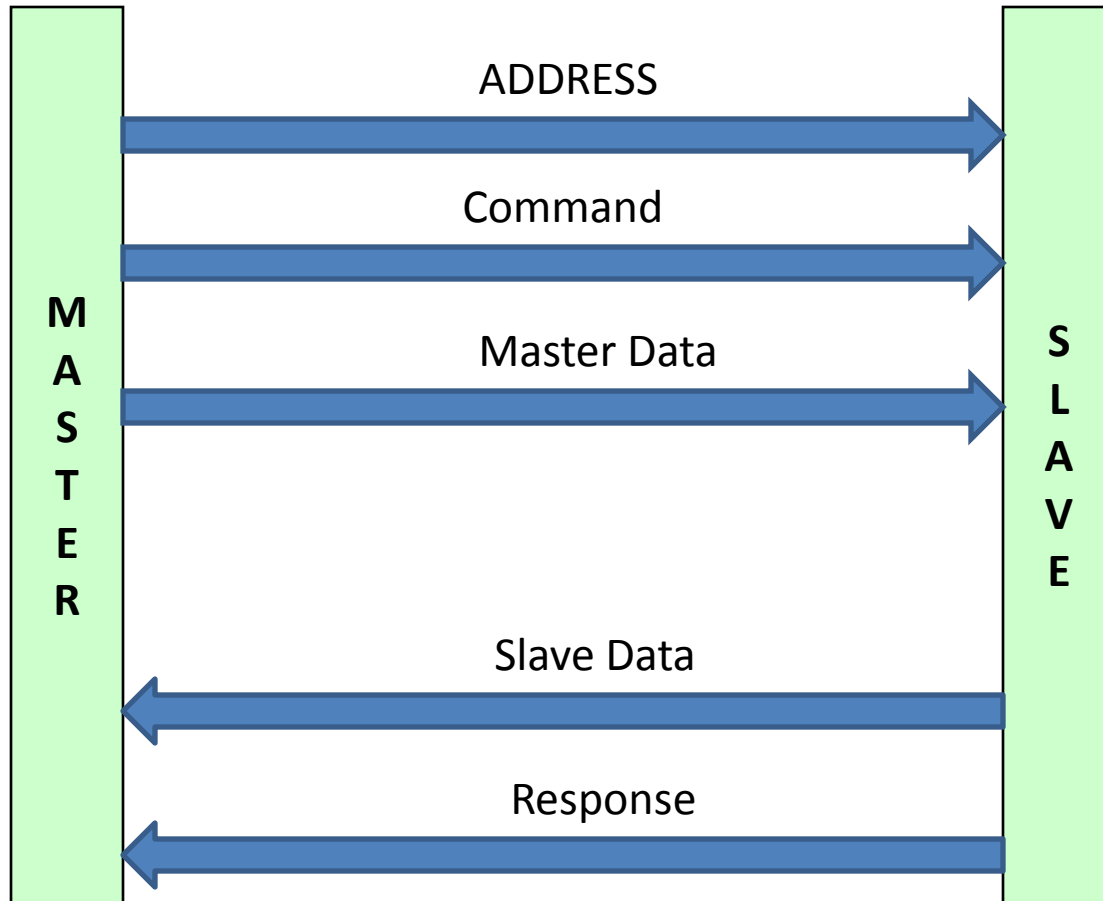

OCP Introduction

- Open Core Protocol International Partnership
 - www.ocpip.org
- *non-profit, open-industry standards body* that promotes and advances the OCP specification
- configurable and highly scalable interface for on-chip subsystem communications
- *openly licensed, core-centric protocol* to meet contemporary system level integration challenges

OCP-IP Version History

Connection , Cache Coherency

2D , MSecure , EnableClk

Tags Extensions

Thread & Burst
Extension

Complex
Extension

OCP 3.0

2009

OCP 2.2

2007

OCP 2.1

2006

OCP 2.0

2003

OCP 1.0

2001

OCP Phase & Group

- OCP Phases
 - Request
 - Response
 - DataHandShake
- OCP Signal Groups
 - Request
 - Response
 - DataHandShake

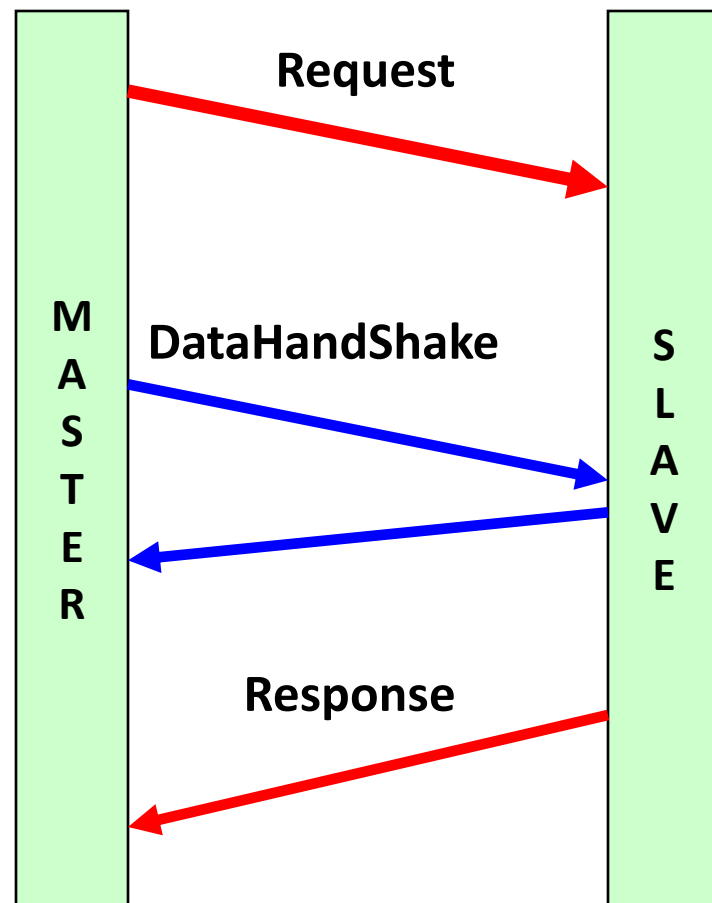

SRMD vs MRMD



Multiple Request
Multiple Data

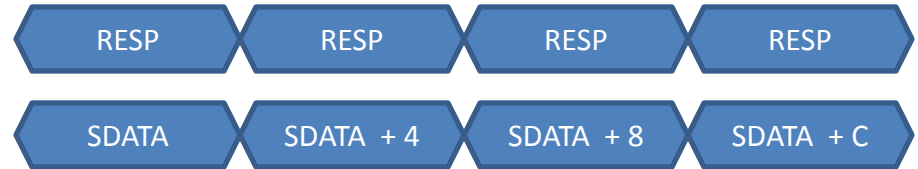

Single Request
Multiple Data

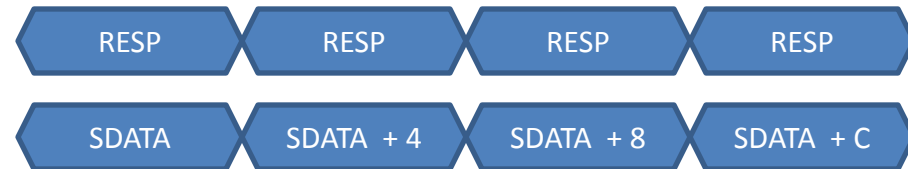

Saving in Power & Better Utilization of the bus

2D addressing example

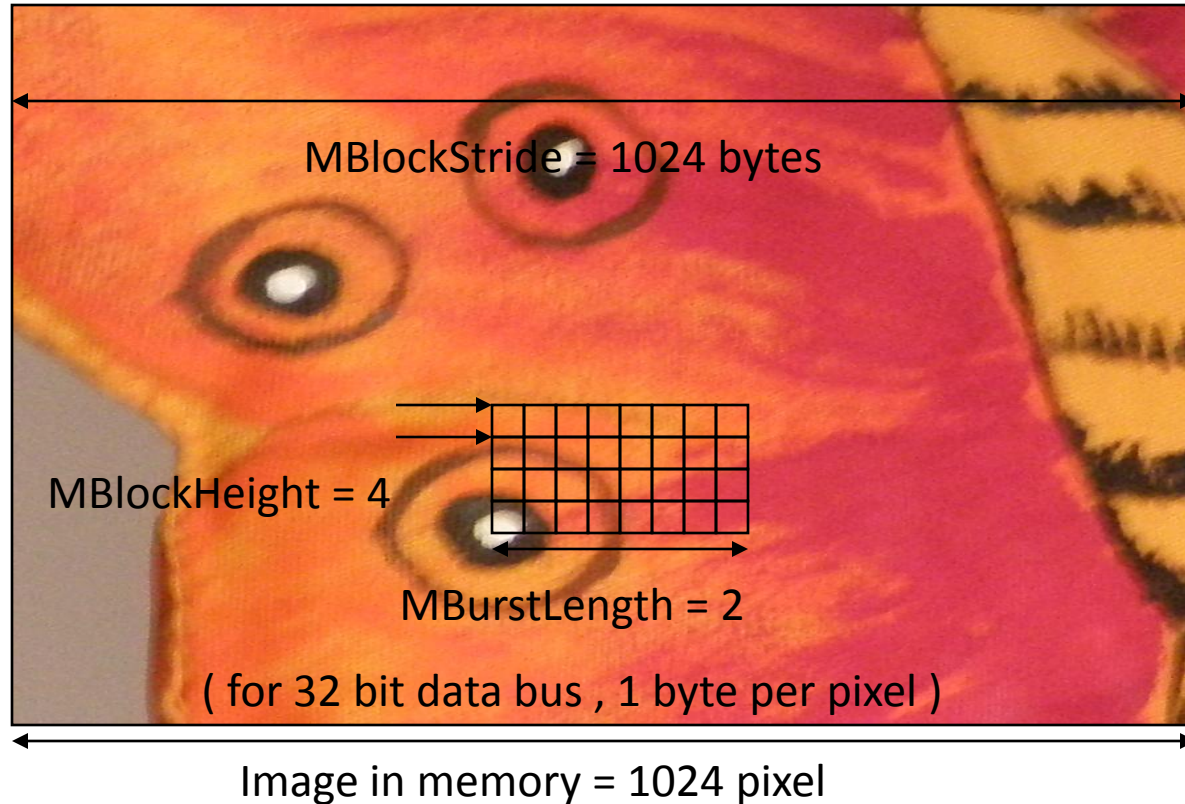

Start Address to next row = Start Address of previous row + MBlockStride

2D data transfer with single request

Tagging vs Threading

- Concurrency in transactions.
- independent flow control for each thread and have no ordering rules for transactions on different threads
- Tags exist within a single thread and are restricted to shared flow control.
- Transfers within a single thread must remain ordered unless tags are used.

Connection Protocol

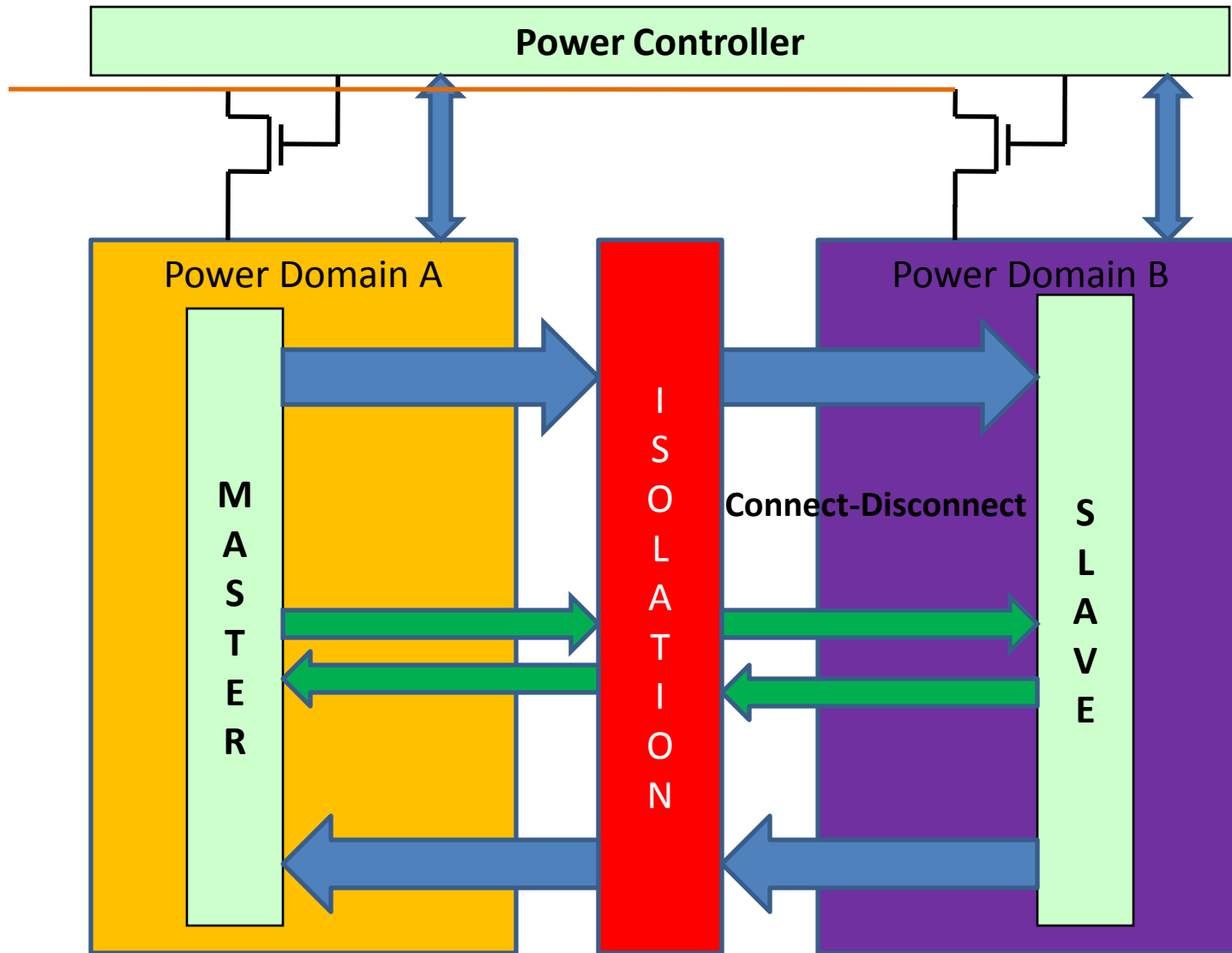

Cache Coherency

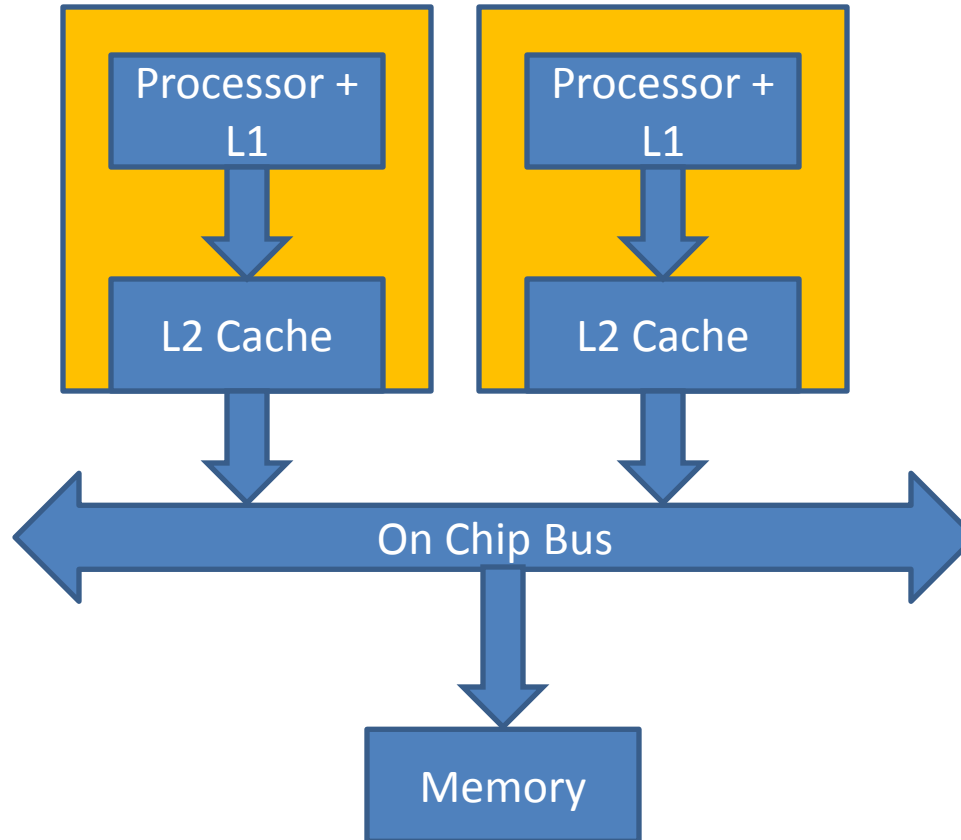

Snoop Based OCP Cache Coherency

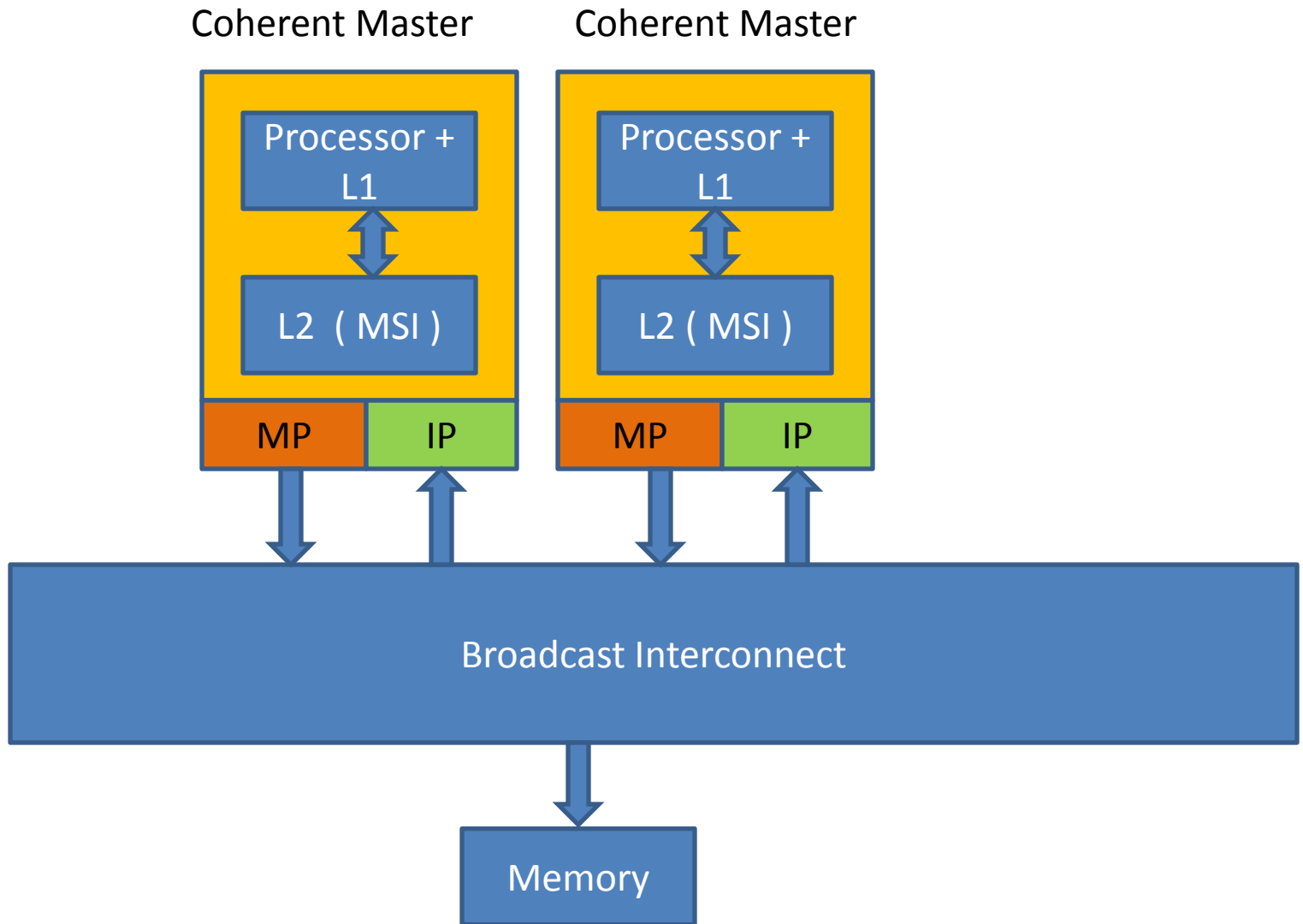

Directory Based OCP Cache Coherency

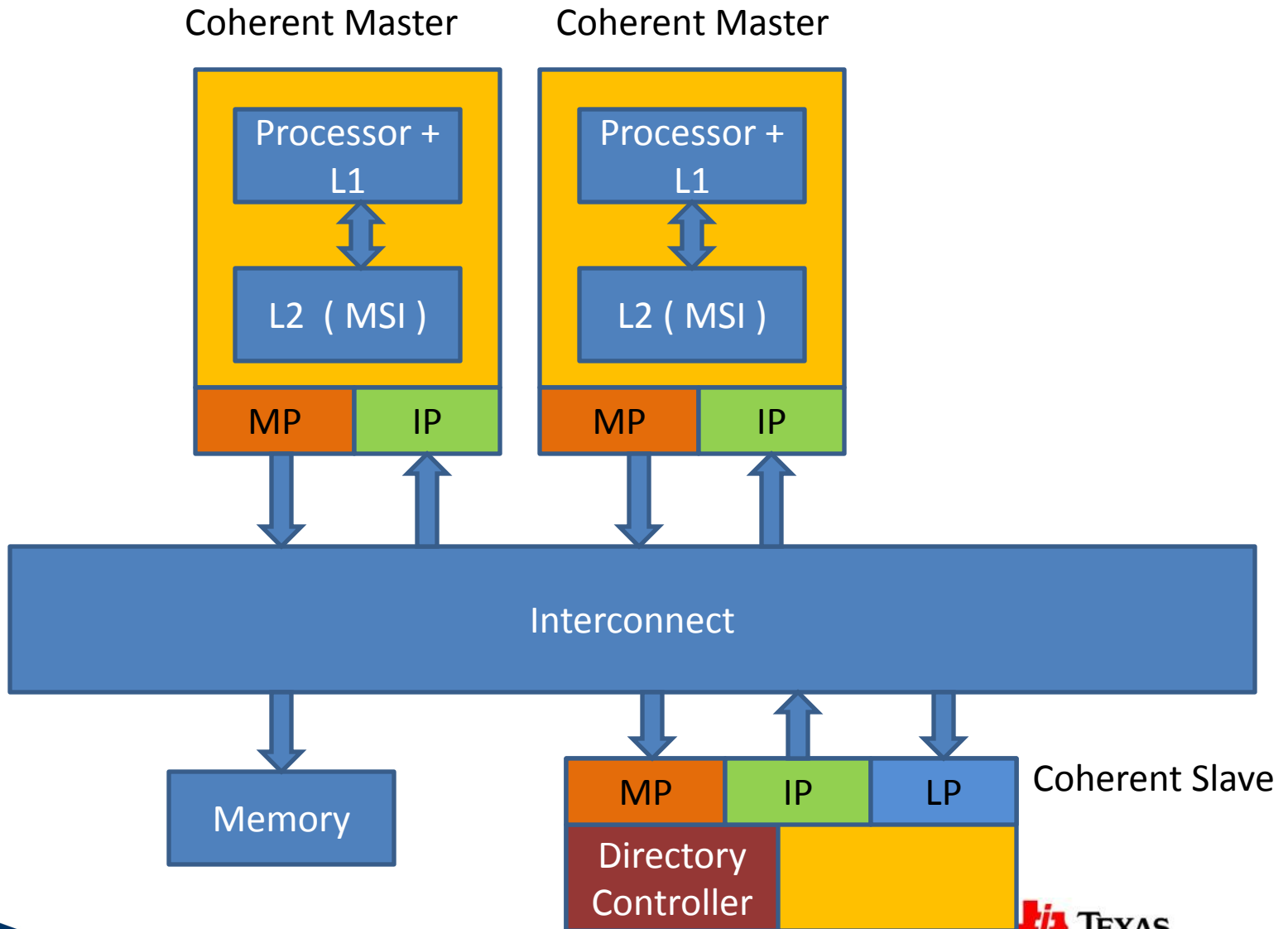

OCP Configurability

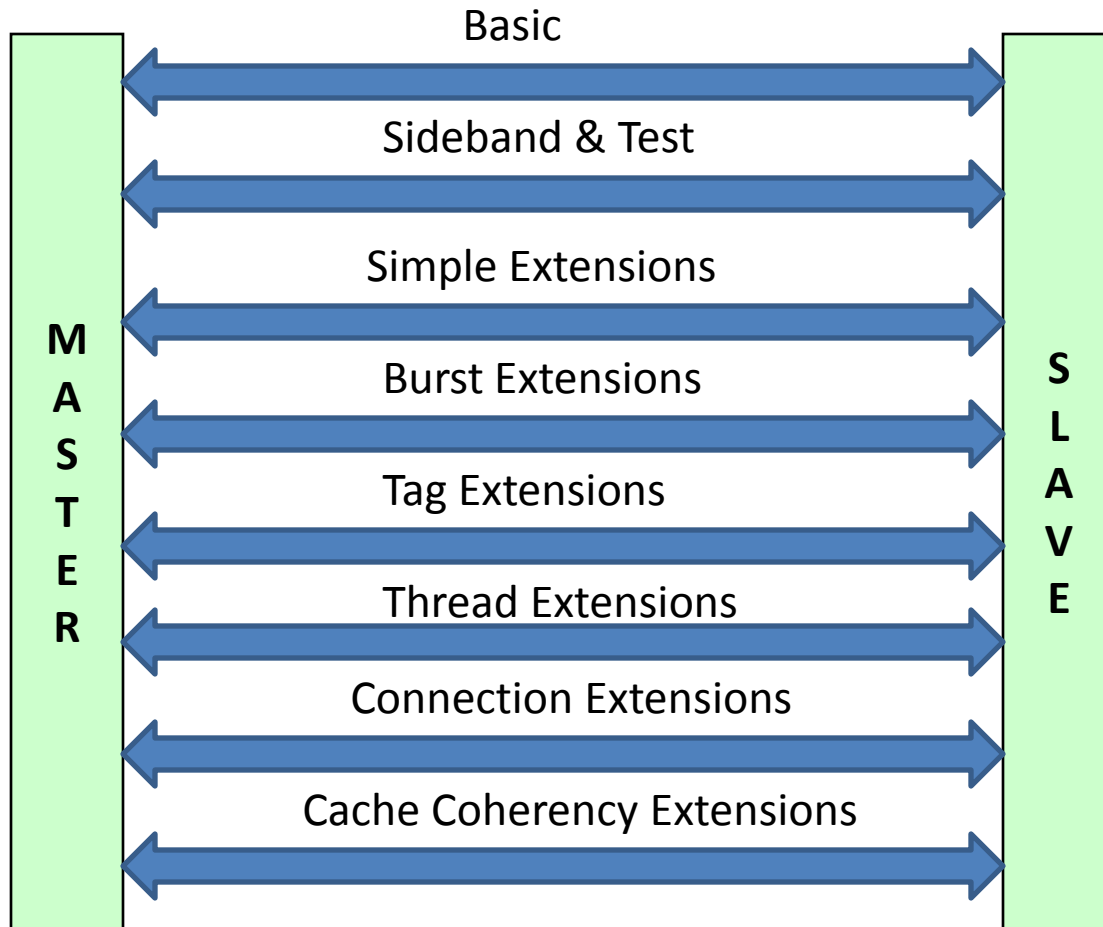

Except Basic Signal Group , all other extensions are optional

OCP Parameters

The OCP-IP Specification defines, for each OCP-IP interface, a certain number of parameters

Table 13 OCP Signal Configuration Parameters

| Group | Signal | Parameter to add signal to interface | Parameter to control width | Default Tie-off |
|--------|--------------------------|--------------------------------------|----------------------------|-----------------|
| Basic | Clk | Required | Fixed | n/a |
| | EnableClk | enableclk | Fixed | 1 |
| | MAddr | addr | addr_width | 0 |
| | MCmd | Required | Fixed | n/a |
| | MData | mdata | data_width | 0 |
| | MDataValid | datahandshake | Fixed | n/a |
| | MRespAccept ¹ | respaccept | Fixed | 1 |
| | SCmdAccept | cmdaccept | Fixed | 1 |
| | SData ¹ | sdata | data_width | 0 |
| | SDataAccept ² | dataaccept | Fixed | 1 |
| | SResp | resp | Fixed | Null |
| Simple | MAddrSpace | addrspace | addrspace_width | 0 |
| | MByteEn ³ | byteen | data_width | all 1s |

OCP-IP Specification: constraints

- The OCP-IP Specification also defines a certain number of constraints between parameters checking the OCP compliancy
- Examples:
 - 2.1.2: *byteen* can only be enable if *sdata* or *mdata* is also enabled
 - 2.1.5: *byteen* is only supported when *data_width* is a multiple of 8
 - 2.1.23: The *burstlength_width* must be 0 if *burstlength* is disabled and must be greater than 1 if *burstlength* is enabled
 - ...

Interface Specification

- IP-XACT standard defines IP meta-data description like interfaces, registers, bit fields in the form of an XML schema. It provides a common and language-neutral way to describe IP, compatible with automated integration techniques and enabling integrators to use IP from multiple sources with IP-XACT enabled tools.
- IP-XACT1.5 version would become IEEE P1685 Standard.

IP-XACT Terminology

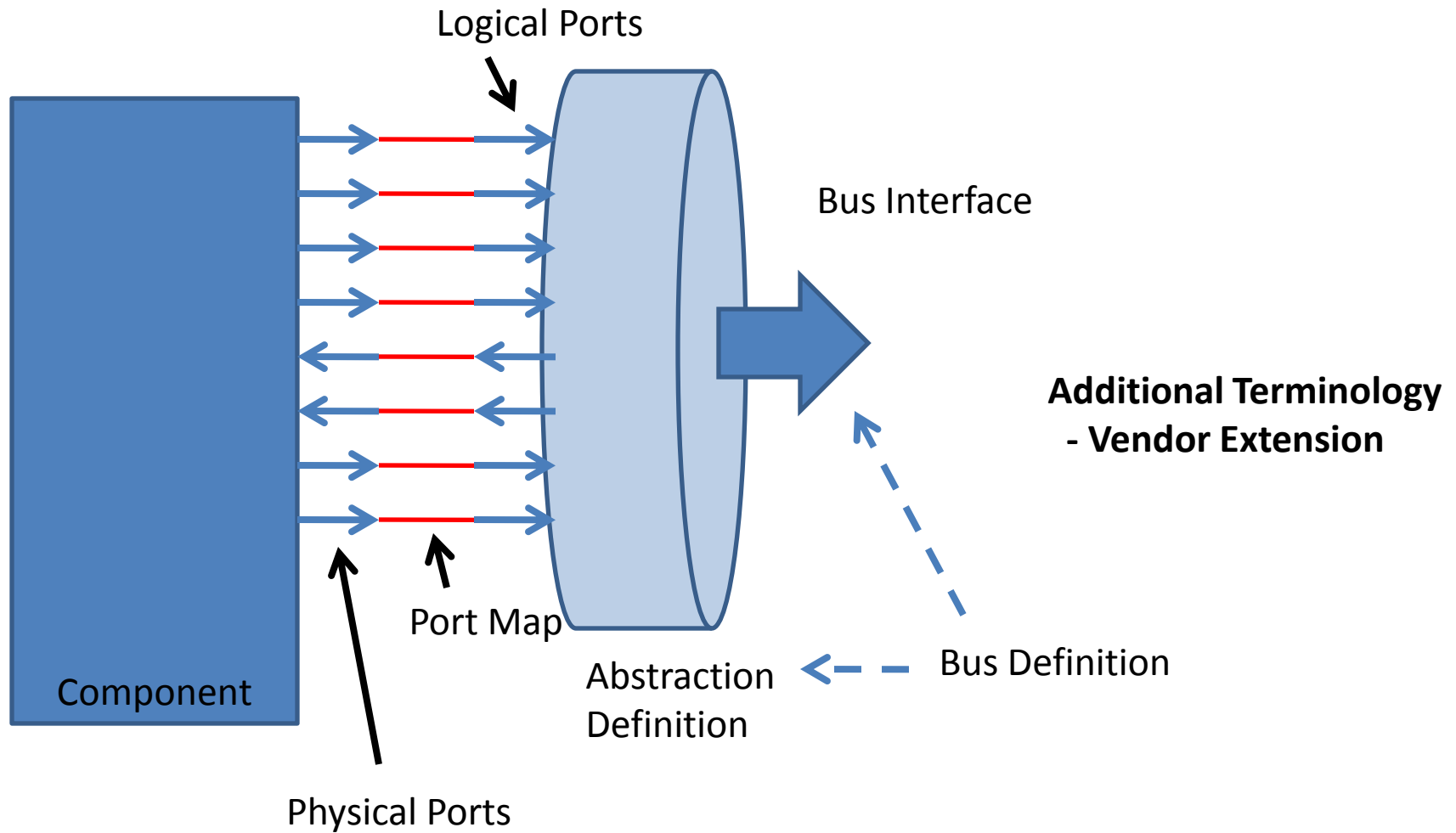

IP-XACT 1.4 OCP Vendor Extensions

The OCP MDWG defined vendor extensions to allow the definition of these parameters and constraints:

- busDefinition defines:
 - OCP parameters (with description, type, default value and associated assertions)
- abstractionDefinition defines:
 - OCP logical ports and associated parameterized constraints:
 - portPresence: constraint indicating when this logical port should be mapped in an OCP busInterface, depending on OCP parameter value(s)
 - portWidth: width constraint of this logical port, depending on OCP parameter values
- component/busInterface:
 - Parameterization of OCP parameters (through standard IP-XACT busInterface parameters)

OCP logical port definition (in abstractionDef)

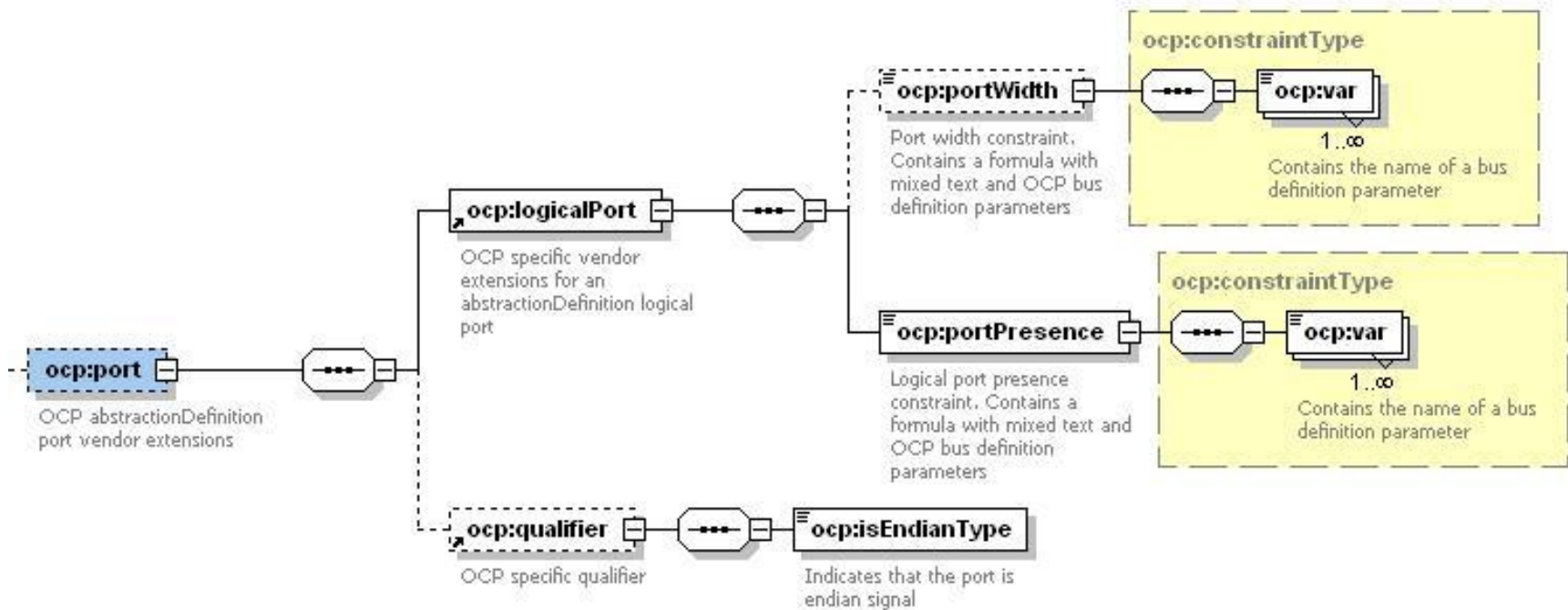

OCP Parameter definition (in busDefinition)

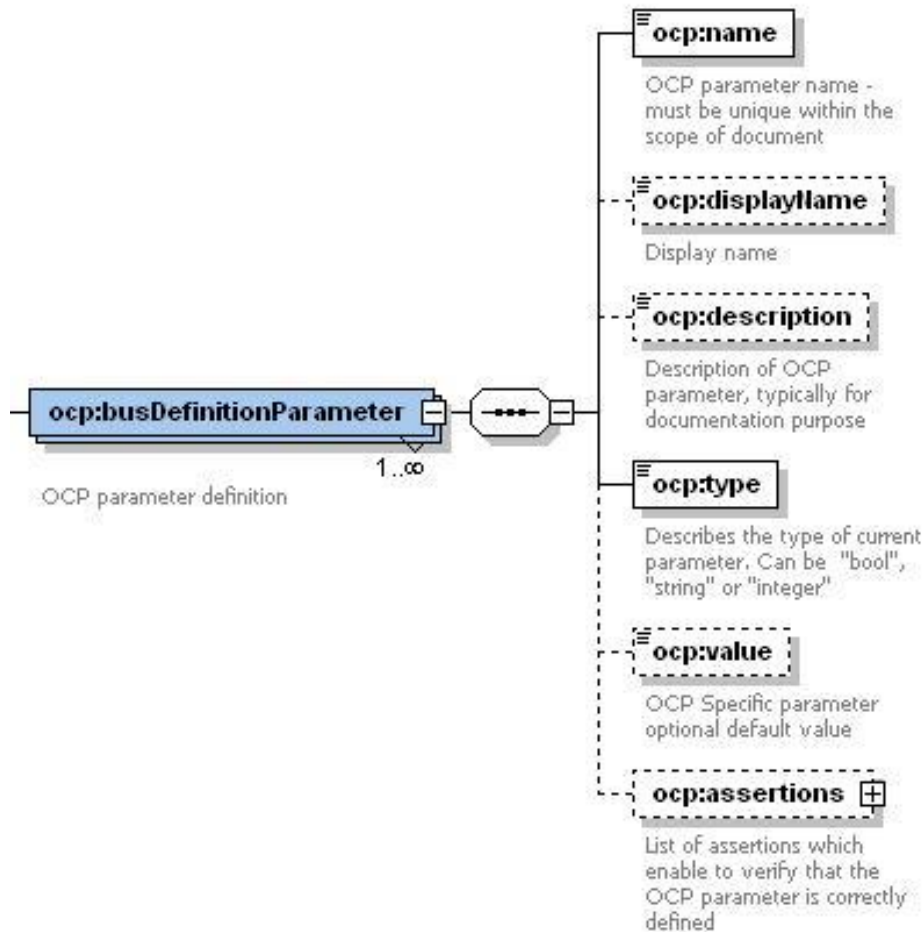

OCP Parameter Assertions (in OCP parameter)

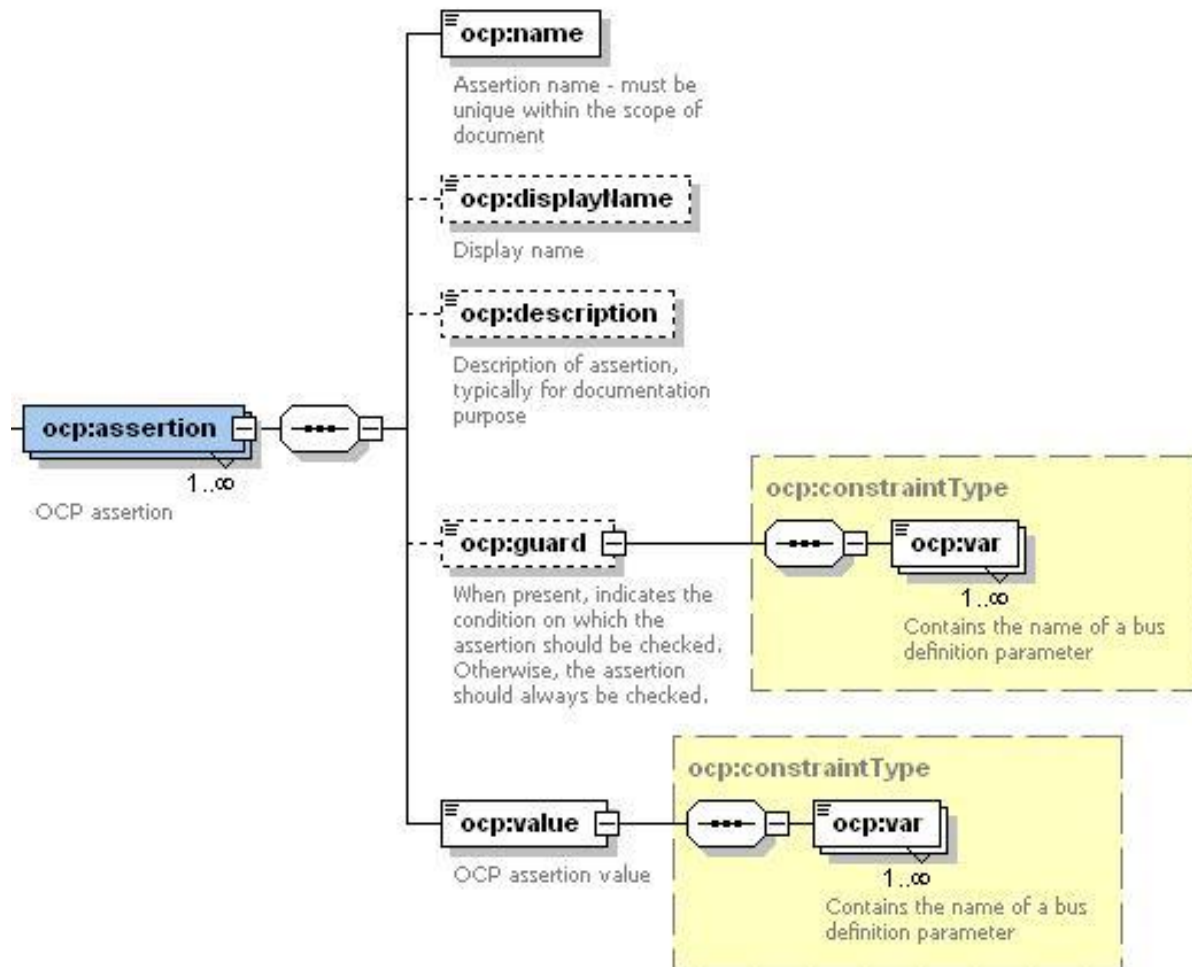

IP-XACT 1.4 OCP Vendor Extensions

- Implementation of the assertions and constraints (ocpPresence, ocpWidth and ocpAssertions) are done using Xpath expression with mixed-content type (allowing to mix text and elements)
- Allows automatic consistency checks by tools between busInterface definition and OCP parameters, and checks the OCP parameter configuration
- We have implemented an XSLT checker in 2 steps:
 - A first XSLT is extracting the information from the bus and abstraction definition to create an XSLT checker
 - The XSLT checker can be run on any component to check that each OCP bus interface is OCP compliant

Conclusion

- The Open Core Protocol
 - Achieves the goal of IP design reuse. The OCP transforms IP cores, making them independent of the architecture and design of the systems in which they are used.
 - Optimizes die area by configuring into the OCP interfaces only those features needed by the communicating cores.
 - Simplifies system verification and testing by providing a firm boundary around each IP core that can be observed, controlled, and validated.
 - Provides tools to validate the OCP interface configuration to ensure rapid creation and integration of interoperable components in industry standard tools.

Thank You

Visit ww.ocpip.org to join & get benefit from the OCP-IP community.

References

- OCP3.0 specification (www.ocpip.org)
- Using OCP and Coherence Extensions to Support System-Level Cache Coherence by Chien-Chun (Joe) Chou, Sonics, Inc.; Konstantinos Aisopos, EE Dept., Princeton University; David Lau, MIPS Technologies; Yasuhiko Kurosawa, Toshiba Corporation; and D. N. (Jay) Jayasimha, Sonics, Inc
http://www.ocpip.org/uploads/documents/OCP_Cache_Coherence_1.pdf
- Spirit Consortium Documents
<http://www.spiritconsortium.org/tech/docs/>
- Viewpoint: Capture OCP systems in IP-XACT 1.4 by Stéphane Guntz
<http://eetimes.eu/showArticle.jhtml?articleID=218101268&queryText=spec>
- *IPXACT_representation_of_OCP* By Stephane Guntz (Magillem Design Services), Christophe Amerijckx (STMicroelectronics), Pascal Chauvet /Kamil Synek (Sonics), Prashant Karandikar (Texas Instruments), Vesa Lahtinen (Nokia), Mark Noll (Synopsys)
http://www.ocpip.org/uploads/documents/IPXACT_representation_of_OCP_20081201.pps